

**ISAIAH PLEADS FOR GOD'S MERCY**

Old Testament Lesson #173

Isaiah was a prophet who taught during the reign of several kings in the southern kingdom of Judah. They included: Uzziah, Jotham, Ahaz, and Hezekiah (Is. 1:1). During the many years that Isaiah worked for God, he saw the nation of Judah struggling many times with disobedience to God's commandments. Because of their behavior, God caused judgments to be made against Judah.

Isaiah appreciated our position before God. He knew that God was Judah's Father. He writes in Isaiah 64, "O LORD, you are our Father. We are the clay, you are the potter; we are all the work of your hand" (v. 8). Isaiah understood how God was their creator, and everything was in His control.

The people needed God, as their Father, on their side. However, they continued to sin against him. The people no longer called on God's name, and God had hidden his face from them. Isaiah did not want God to turn from them and ignore them. He knew that Judah's sins caused God to stop helping and protecting them. Earlier Isaiah wrote, "Surely the arm of the LORD is not too short to save nor his ear too dull to hear. But your iniquities have separated you from your God; your sins have hidden his face from you, so that he will not hear" (Is. 59:1-2).

Isaiah knew that for Judah to continue to be blessed by God they needed to acknowledge their sin to God and to ask for His forgiveness. It is here in Isaiah 64 that Isaiah himself prays to God on behalf of himself and the people. He says, "Do not be angry beyond measure, O LORD; do not remember our sins forever. Oh, look upon us, we pray, for we are all your people" (v. 9).

All of the opening verses of this chapter form part of Isaiah's prayer. He is asking God to "rend the heavens and come down." He wants God to intervene in the affairs of the nation and to deliver them. He describes God's awesome power, how the "mountains would tremble before" Him. He wants God's name to be made "known to your enemies and cause the nations to quake before you" (v. 2).

From the beginning of time, there has been no one who has seen anything or perceived anything as good as what God has done on behalf of His people, "those who wait for him" (v. 4). As children, we can think of a lot of really neat things that we'd like someone to do for us. None of those things will ever compare to the goodness that God has done on behalf of others, and those things He will do in the future!

Like Isaiah, as children we need to always look to God for help. He is our God and we are the work of His hand. He will "come to the help of those who gladly do right, who remember your (God's) ways" (v. 5).

**POINTS TO CONSIDER:**

- The description of God as the potter is one that appears elsewhere in the scriptures. Earlier Isaiah wrote of this in Isaiah 45:9. The Jeremiah also uses this analogy in his prophecy. Compare his words as recorded in Jeremiah 18:1-10. In addition, the Apostle Paul appears to make reference Isaiah 64:8 in his letter to the Romans. In Romans 9:21 he writes, "Does not the potter have the right to make out of the same lump of clay some pottery for noble purposes and some for common use?"
- Isaiah 64:4 is cited by the Apostle Paul in 1 Corinthians 2:9, "However, as it is written: 'No eye has seen, no ear has heard, no mind has conceived what God has prepared for those who love him.'"

**ANSWER KEY:**

"We are the clay, You are the potter; we are all the work of Your hand."

"Oh, look upon us, we pray, for we are all Your people."

**G**od is our Father. In Isaiah 64:8 Isaiah tells us about our relationship with God.

Match the number with the word given.

“  
 \_\_\_\_\_ 8 \_\_\_\_\_ 4 \_\_\_\_\_ 12 \_\_\_\_\_ 5 \_\_\_\_\_ 14 \_\_\_\_\_ 2 \_\_\_\_\_ 11  
 \_\_\_\_\_ 7 \_\_\_\_\_ 13 \_\_\_\_\_ 3 \_\_\_\_\_ 1 \_\_\_\_\_ 10 \_\_\_\_\_ 9 \_\_\_\_\_ 15  
 \_\_\_\_\_ 16 \_\_\_\_\_ 6 \_\_\_\_\_  
 ” —Isaiah 64:8

Cross out the letters b and c and fill in the blanks below to read Isaiah's prayer.

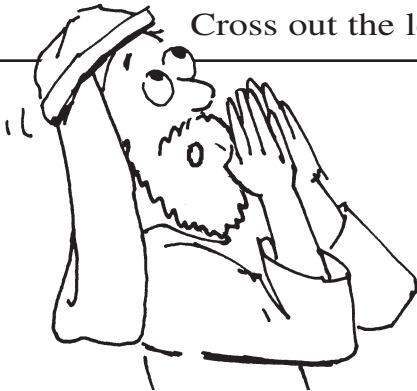

O	b	h	l	o	c	o	b	k	u	p	b	o	b	n
c	c	u	b	c	s	w	b	c	e	p	c	r	a	y
c	f	b	c	o	c	r	b	w	e	b	c	c	b	b
a	b	r	e	c	b	a	b	l	c	b	l	c	b	b
b	Y	c	o	u	b	r	c	p	e	b	o	p	l	e

“ \_\_\_\_\_ , \_\_\_\_\_ , \_\_\_\_\_ , \_\_\_\_\_  
 \_\_\_\_\_ ”

Name \_\_\_\_\_

**G**od is our Father. We are like clay and God is our potter.

Connect the dots. 1 2 3 4 5 6 7 8 9 10 11 12 Trace the word.

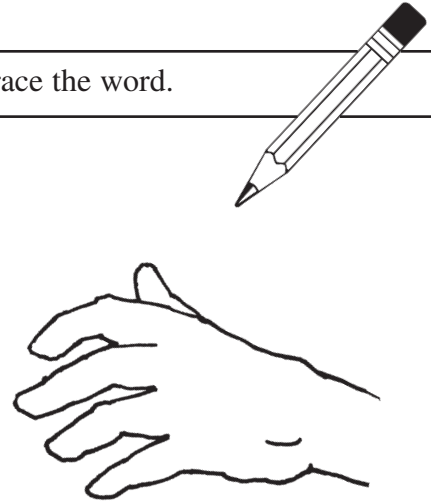
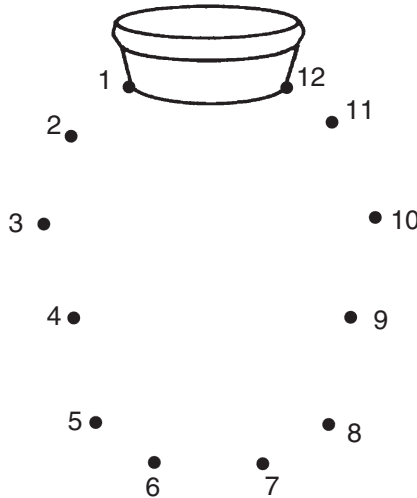

We are all the work of His

hand.

Circle the pictures that are the same.



Name \_\_\_\_\_